

Silicon-Gate Switching Functions Optimize Data Acquisition Front Ends

Jack Armijos and Kevin Smith

The trend in data acquisition is moving toward ever-increasing accuracy. Twelve-bit resolution is now the norm, and sixteen bits are not uncommon. Along with this precision, throughput is also very important. When monitoring several hundred channels, sample rates in the hundreds of kilohertz are not only desirable but, in many cases, mandatory.

Analog switches and analog multiplexers find extensive use at the heart of most data acquisition and process control systems. This application note provides useful information about the new high-performance DG400 family of devices. It also reviews many design considerations that will enable you to get the best performance in your data acquisition designs.

Silicon-Gate Technology

Siliconix’s advanced high-voltage silicon-gate CMOS processing brings many benefits to the DG400 family of analog switches and multiplexers: fast switching speed, low power consumption, low charge injection, low leakage, and TTL compatibility. In addition, this family works with reduced or single power supplies.

The metal-gate process (Figure 1) requires that the gate overlap with the drain and source areas to assure reliable operation even when misalignments occur during masking

operations. This produces high gate-drain and gate-source capacitances. The silicon-gate process, on the other hand, is self-aligning in that it uses the silicon gate itself as a mask for source and drain diffusions. This produces minimal overlap, resulting in much smaller parasitic capacitances. Because the silicon-gate process is more tightly controlled than the older metal-gate technologies, individual devices can be spaced closer together, resulting in smaller die that achieve equivalent performance.

ESD Tolerance

Electrostatic discharge (ESD) has caused many CMOS device failures, both during manufacture and during handling or PC board assembly. Historically, CMOS devices have shown an electrostatic discharge sensitivity (ESDS) in the ± 500 Volt range, which was insufficient in many cases. However, the DG400 family incorporates specially designed ESD protection. These devices have been evaluated using the electrostatic discharge sensitivity (ESDS) test circuit of MIL-STD-883, Method 3015 (100-pF capacitor discharged through a 1.5-k Ω resistor). The DG4XX series has a typical overall tolerance of 1000 V. However, ESD tests on the source/drain—with the power supply pins bypassed or shortened—show that the DG400 through DG405 have tolerances of more than ± 2000 V, whereas the DG408 through DG419 withstand $> \pm 4000$ V.

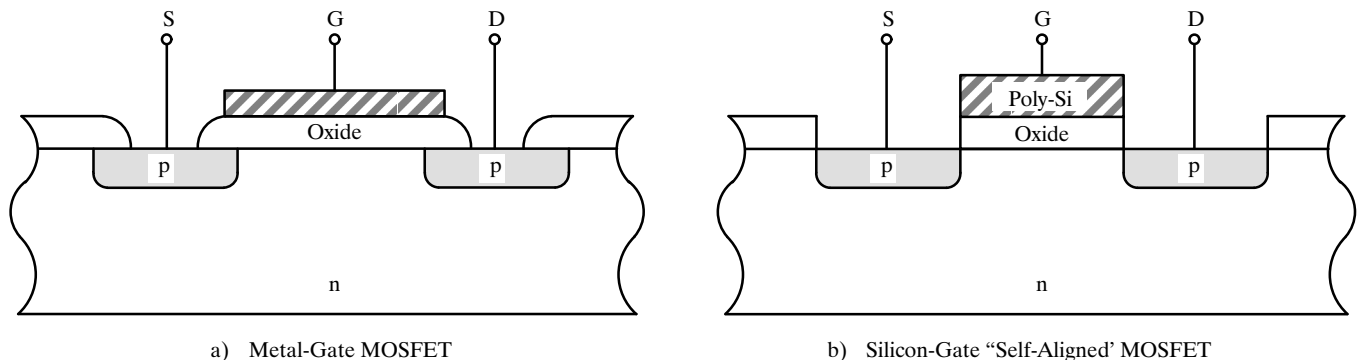

Figure 1. Comparison of Metal and Silicon-Gate Structures

Typical Data Acquisition System

Figure 2 shows the block diagram of a typical data acquisition system. Analog inputs are converted to a digital format that allows a computer to gather, monitor, display, and analyze the collected data. If the system has digital output capabilities, the computer can be used to accurately control your process so it will run at maximum efficiency. For example, it can react to the input data to maintain a constant temperature, to control flow rates in accordance to a predetermined schedule, etc.

This system accepts analog voltage inputs that can come from temperature sensors, pressure transducers, flow meters, or from optional signal conditioners or remote current-mode transmitters. The signal conditioning stages can perform preamplification, scaling, and multiplexing, and can also provide galvanic isolation or overvoltage protection. The analog multiplexer is basically a monolithic array of analog switches with on-chip address decode logic. The multiplexer is a cost-effective solution that shares the more expensive sample-and-hold (S/H) and analog-to-digital converter (ADC) functions among several inputs. The programmable-gain amplifier's (PGA) purpose is to amplify low-level signals to increase measurement resolution and accuracy. The S/H circuit quickly captures a sample of the analog input signal and holds its instantaneous value for a time that is long enough to allow for the ADC acquisition time to be completed.

Operation of the analog front end is governed by means of a digital controller which, in turn, interfaces to a host computer or microprocessor. Digital event inputs or interrupts go directly to the controller, and its digital outputs provide the feedback necessary to perform automatic process control. In addition to the analog multiplexer, analog switches are found in the PGA, S/H, and ADC circuits. The following paragraphs will review many design considerations as we proceed to the design and evaluation of an experimental data acquisition system front end.

Designing an Experimental Temperature Monitoring System

The purpose of our experimental circuit is to evaluate some of the errors introduced while monitoring temperature via three popular types of transducers: a two-terminal integrated circuit, a resistive temperature detector (RTD), and a type J thermocouple. In addition, we want to sample ground and a +5 Volt reference voltage. These two quantities may be used for calibration and error correction purposes. Signals from the sensors will arrive at the PC board via twisted pair wires to help eliminate any common-mode noise. No cold-junction compensation of the thermocouple will be attempted since compensation circuits are readily available. The schematic diagram is shown in Figure 3.

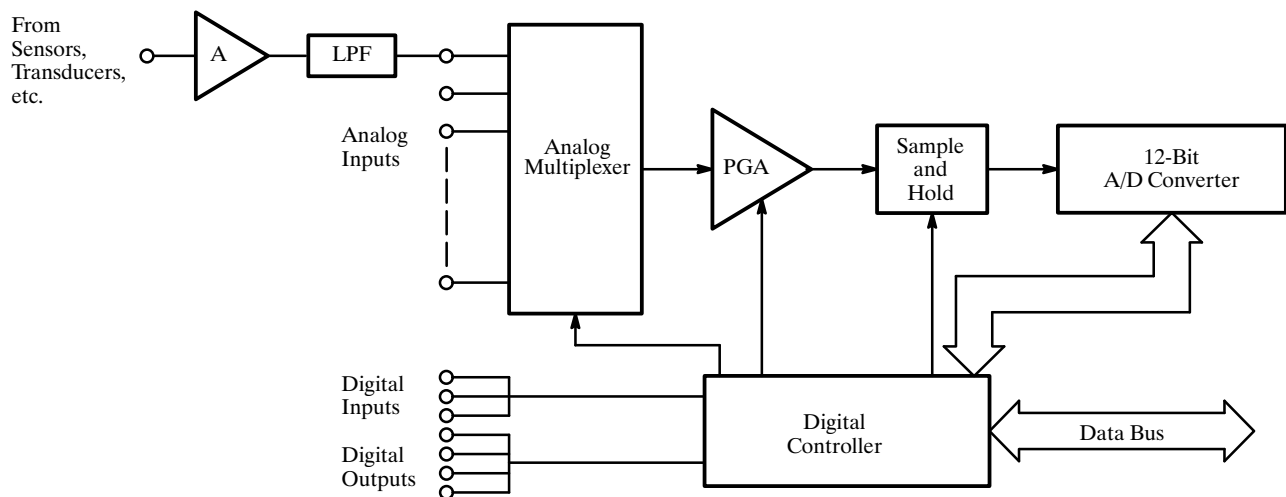

Figure 2. A Typical Data Acquisition System

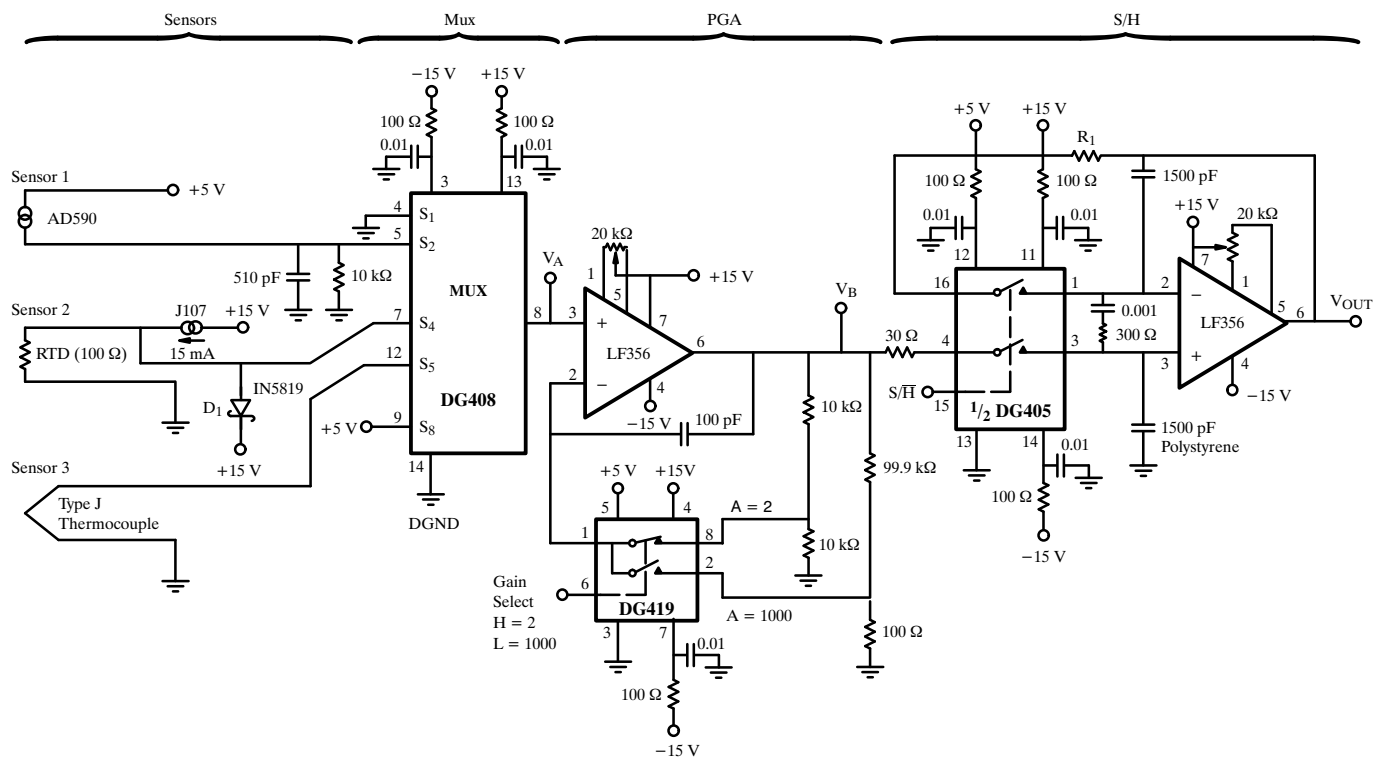

Figure 3. Temperature Monitoring Circuit

The Multiplexer

The DG408 is an 8-channel single-ended multiplexer with an on-chip logic reference that maintains TTL compatibility over a wide range of power supply voltages. Its low on-resistance and low leakage (see Figure 4)

minimize static errors. The worst-case error due to leakage is given by

$$V_{e \max} \approx 40 \Omega \times 100 \text{ pA} \approx 4 \text{ nV}$$

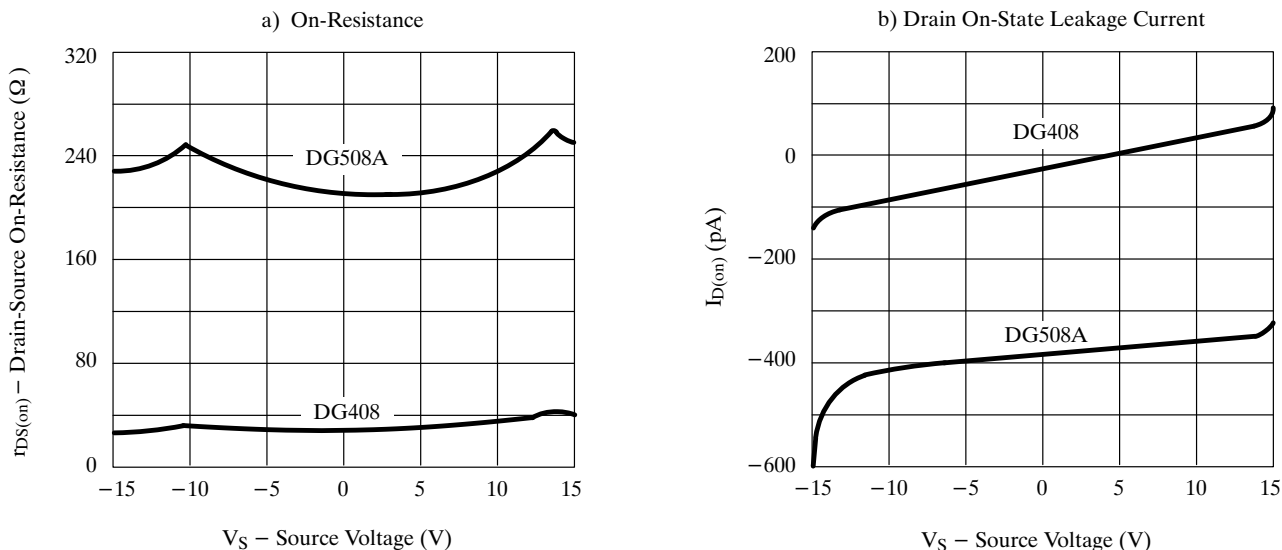

Figure 4. DG408 Typical Characteristics

Figure 5 shows a thermocouple representation of one switch in the multiplexer. If connections J_{1S} and J_{1D} are at the same temperature, their thermoelectric EMFs will cancel out. If a temperature gradient exists between side “S” and side “D,” the voltages will not exactly cancel, and a net error voltage will result. Therefore, the multiplexer should be mounted in a thermally stable environment—that is, soldered to the PCB board and away from hot components and air drafts. The DG408, thanks to its low power dissipation (~ 1 mW), develops less than ± 1 μ V in still air at room temperature. When heated to 85°C with a thermal probe, the error becomes as large as 100 μ V. On-resistance ($r_{DS(on)}$) matching is necessary when the $r_{DS(on)}$ of the multiplexer is significant when compared to the rest of the circuit, such as when using differential multiplexing or when the transducer is connected in a resistive bridge configuration. Having smaller $r_{DS(on)}$, the DG408 offers also an “ $r_{DS(on)}$ matching” specification which is three times better than the DG508 in terms of the magnitude of resistance.

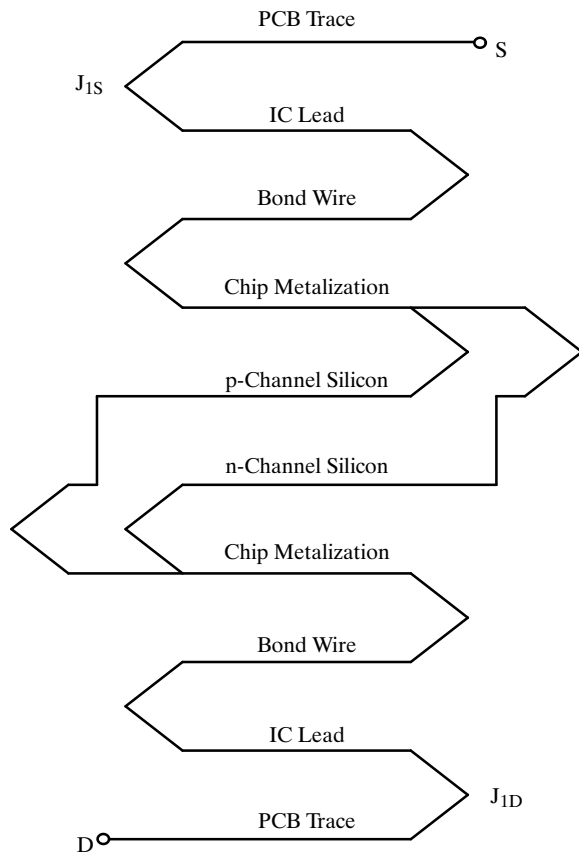

Figure 5. Thermocouple Representation of a CMOS Multiplexer Switch

The Programmable Gain Amplifier

There are several types of gain-ranging circuits. Although it would be impossible to cover them all here, Figure 6 shows two of the most common types. Each of these types has advantages and disadvantages.

Figure 6a shows a circuit which uses three resistors and two switches. By closing one switch at a time, two different gains can be selected. By closing more than one switch at a time, three gain combinations are possible.

The circuit in Figure 6b uses four resistors to achieve the same two gain values as the previous example.

In comparing the two circuits, it would seem that the first circuit is the better of the two since it requires fewer resistors. Upon closer examination, however, we find that there’s more to consider. In Figure 6a, the analog switch is in series with the feedback resistor. This means that the $r_{DS(on)}$ of the switch is part of the feedback ratio. Instead of the gain being $A_V = -R_f/R_1$, it becomes

$$A_V = -(R_f + r_{DS(on)})/R_1$$

While the lower on-resistance and lower $\Delta r_{DS(on)}$ of the DG400 family of switches do offer advantages over older metal-gate switches, in this situation, it would be better still if we could eliminate the effect of the switch $r_{DS(on)}$ altogether. This is where the circuit shown in Figure 6b has an advantage.

As shown in Figure 6b, the gain in each stage is determined by the two resistors in that branch. For the gain of 10, for example, the gain is

$$A_V = (R_{f1} + R_{g1})/R_{g1} = (18 + 2)/2 = 10$$

The $r_{DS(on)}$ of the switch has no affect at all on the gain! However, the switch leakage current may affect the circuit accuracy. Here, again, the DG400 family of switches have an advantage because their leakage current is much lower than the metal-gate switches. By choosing precision resistors or resistor networks, it is possible to have gains accurate to the 12-bit level.

The output voltages of the AD590 and RTD in Figure 3 are greater than 1 V in the temperature range used. The thermocouple, however, had an output voltage that varied from a few microvolts to several millivolts. Therefore, two different gains are required from the PGA: a relatively low gain of two for the AD590 and RTD, and a gain of 1000 for the thermocouple. This allows the voltages to the sample-and-hold to be large enough that any errors contributed by the circuit would have minimal effect.

The DG419 used to select the gain is a very low-power, high-speed switch. An additional benefit of this particular switch is its compact 8-pin package

The 30-Ω resistor serves two purposes. It limits the current through the $\frac{1}{2}$ DG405 to less than its 100-mA (maximum pulsed) rating and also helps to decouple the PGA output from the capacitive load, preventing oscillations.

For best results, in applications where high gains are required due to very low-level transducer outputs, as with strain gages and thermocouples, the signal path to the PGA should be differential.

The Sample-and-Hold Circuit

The sample-and-hold (S/H) circuit uses a $\frac{1}{2}$ DG405, a fast ($t_{ON} < 250$ ns) switch. In this circuit, the two switch sections are at similar potentials in the sample mode, so when they open, they create similar charge injections which tend to cancel each other, therefore, helping to minimize the step error. R_1 can be trimmed to obtain the best possible charge injection cancellation. During the hold mode, the dual switch arrangement also helps to reduce the droop rate. Figure 7 is a scope plot that illustrates the S/H action. Note that acquisition time is a function of the output amplifier's slew rate and settling time.

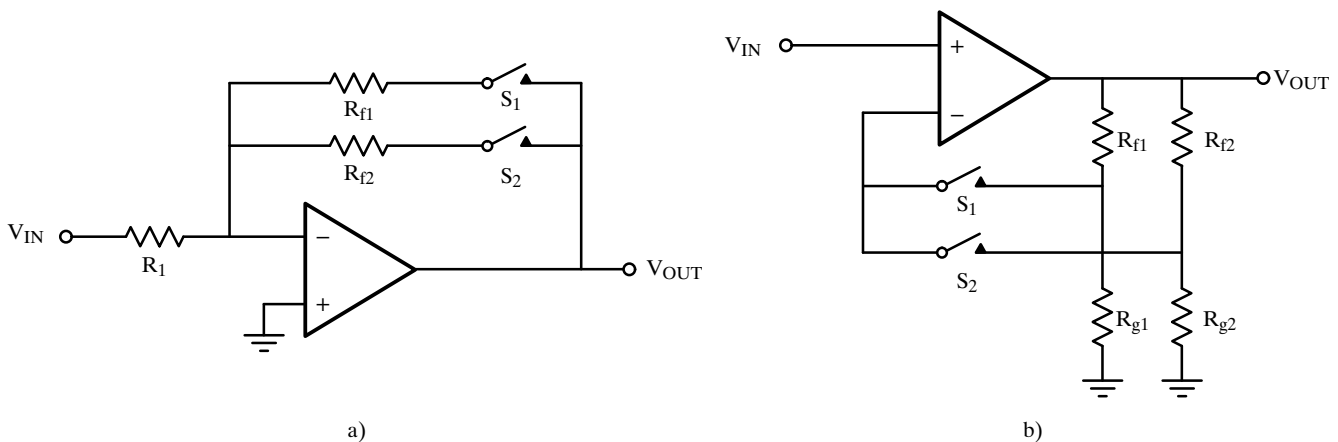

Figure 6. DG408 Typical Characteristics

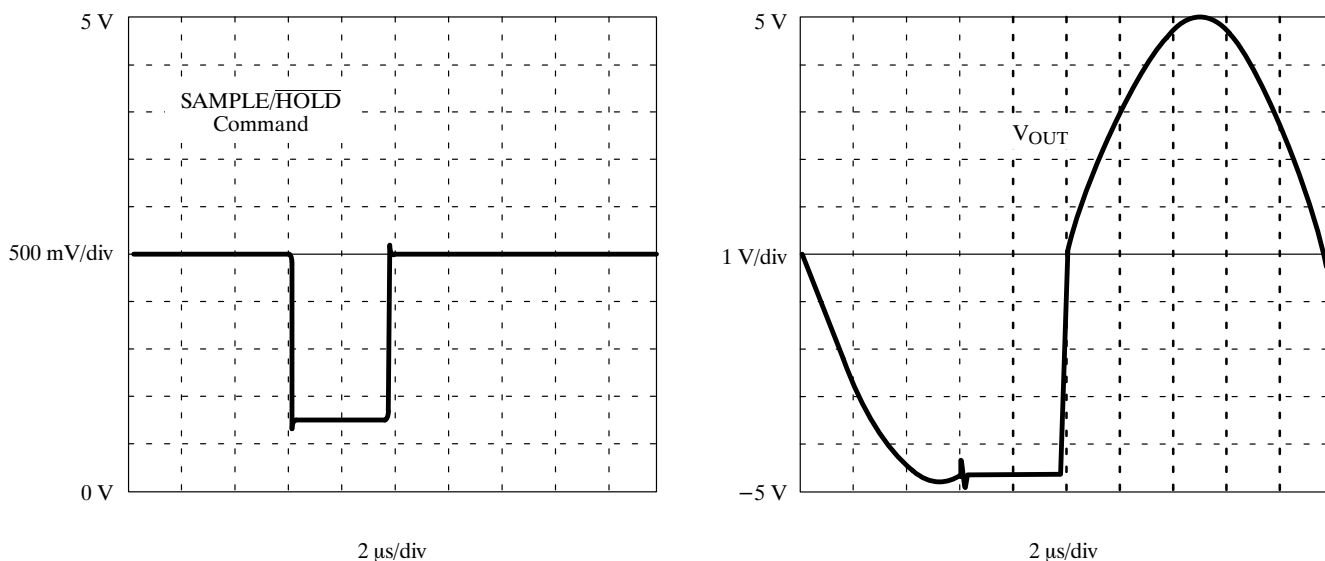

Figure 7. Acquisition Time Depends on Amplifier Slew Rate

AN203

Evaluation Results

Figure 8 shows the transfer characteristics obtained for the three different temperature sensors used. Curve (c) is produced by the “mV output” of a digital thermometer, using the same thermocouple that produced curve (d). Notice the effect that the cold-junction compensation has on the curve (i.e., it causes a 0-V output at 0°C).

As far as resolution is concerned, all three sensors showed satisfactory results for the 0 to 100°C range evaluated. The thermocouple output gave a resolution equivalent to 0.05°C/bit in a 12-bit system. The RTD and AD590 outputs, as configured, only gave the equivalent of 0.5°C/bit and 1°C/bit resolution, respectively. However, depending on the temperature range of interest, this circuit can be modified to produce a larger ΔV and offer a resolution equivalent to 0.01°C/bit.

Figure 9 shows the waveforms obtained when switching back and forth between channel S₂ (AD590) and S₄ (RTD). Note that the PGA output takes longer to settle when the AD590 is selected. On the other hand, the lower output impedance of the RTD sensor makes the PGA output settle about three times faster. From these waveforms, we can estimate the throughput of the system. Allowing 20 μ s for settling times and assuming a 12-bit A/D converter with a 15- μ s conversion time,

$$\text{Throughput rate} = 1/35 \mu\text{s} = \sim 28 \text{ kHz}$$

Precision will depend on the method used to read the transfer characteristics. Factors such as ADC accuracy, transducer accuracy, noise corruption, leakage throughout the signal path, and amplifier offsets must be considered.

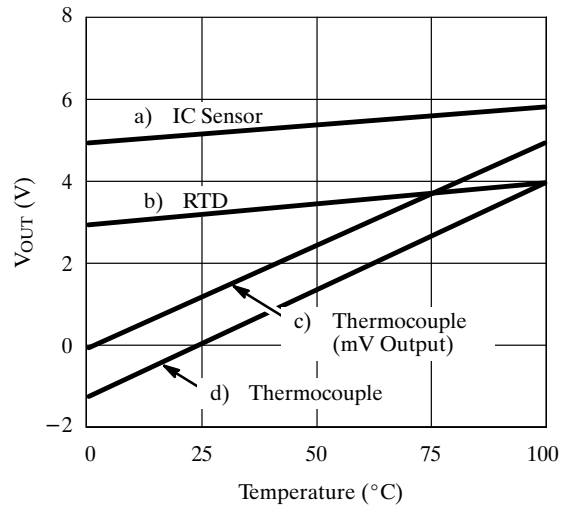

Figure 8. Transfer Characteristics for Various Temperature Sensors

The DG400 switching devices, with their extremely low-leakage specifications and micropower consumptions, practically eliminate leakage and parasitic thermocouple errors. In our case, two transducers outputs are large enough that they are sufficiently free from 60-Hz noise corruption. The thermocouple leads need to be shielded to reduce this problem. Also, a low pass filter is recommended. The amplifiers’ offsets were trimmed out, and the PGA’s gains could also be trimmed. In this case, we selected precision resistors to get within 0.00025% of the target gains desired. The PGA was configured for $A_V = 2$ and the op amp offsets were adjusted with trim pots. In our circuit, we selected AGND at the input to the multiplexer and adjusted the PGA offset for 0 V at its output.

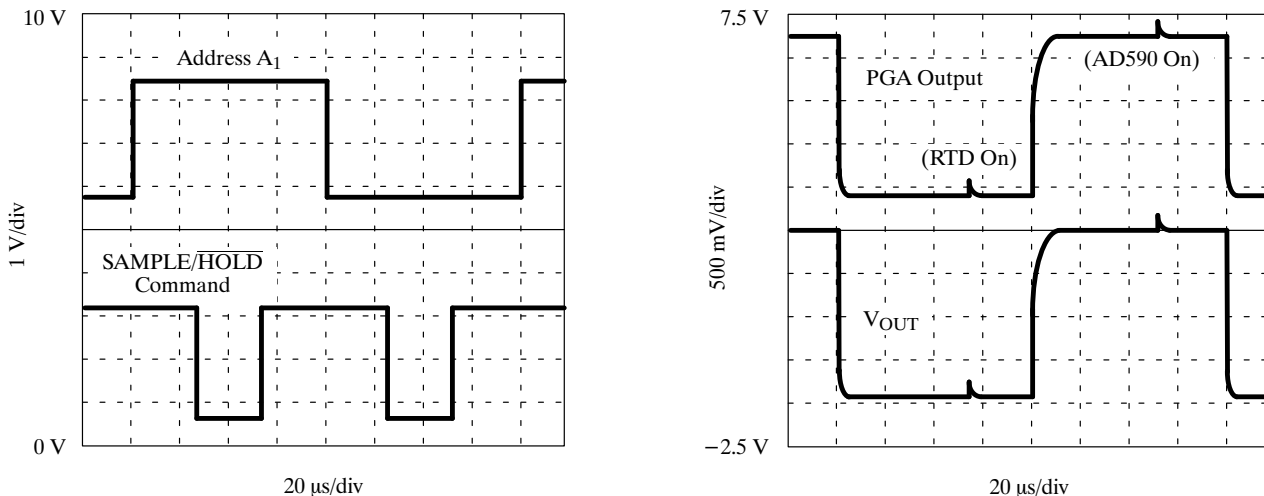

Figure 9. Waveforms Obtained when Monitoring S₂ and S₄ Only

We then adjusted the S/H amplifier offset for 0 V at V_{OUT} . When we switched to $A_V = 1000$, the PGA output went to above 30 mV. In a microprocessor-based system, the amplifier offsets could be compensated in software. This type of correction would also allow the system to compensate for amplifier drifts with time or temperature, which is much more difficult to do using trimpots.

Overvoltage Protection

The supply voltage applied to the constant current source was intentionally raised to +25 V, and the RTD was disconnected. This allowed us to simulate one of those “unlikely” events where the current source would force a voltage on S_4 that is higher than V^+ . This would create an overvoltage condition that won’t damage the multiplexer since the current source does not force more than the absolute maximum current rating (20 mA) into the clamping source-to-substrate diode. However, to prevent the possibility of parasitic transistor action that can cause errors on other channels, a low- V_F (1N5819) Schottky diode (D_1) was installed from S_4 to V^+ . The low forward voltage of the Schottky diverts the overvoltage current so that the clamping diode and its associated parasitic transistors are not activated. Another form of overvoltage protection would be to connect a Zener diode (like a 1N5928) from S_4 to ground to keep the S_4 input voltage below +15 V.

Conclusion

The low $r_{DS(on)}$, low leakage, low power, and high speed of the DG400 family of analog switches and multiplexers improve the performance attainable in precision data gathering systems. Since they are pin-compatible with older metal-gate devices, the DG400 family permits an easy upgrade of many existing designs.

References

1. *Integrated Circuits Data Book, Siliconix incorporated, 1988.*
2. *Interface Magazine, Siliconix incorporated, Winter 1988.*
3. *Omega Temperature Measurement Handbook and Encyclopedia, Vol. 26, 1988.*
4. *Analog Switches and Their Applications, Siliconix, 1980.*
5. *J. Taylor, Computer-Based Data Acquisition Systems Design Techniques, ISA, 1986.*